

Repair Kit 1277D - Cartridge Style 'XT'

For Quatum and Slo-Compression Cartridges

The Kit Contains the following parts for the Style 'XT' Cartridge: **Quantity**

- 93-131NF Packing Set (2)
- 2-043NF O-Ring (2)
- 1-219NF O-Ring (2)
- 1-328NF O-Ring (2)
- 1-021NF Seat Washer (4)
- **333-097NF Stem Nut (new item included)** (4)
 - ◆ Install a new nut each time you remove it for a repair.
The nut should be flush with the stem end.

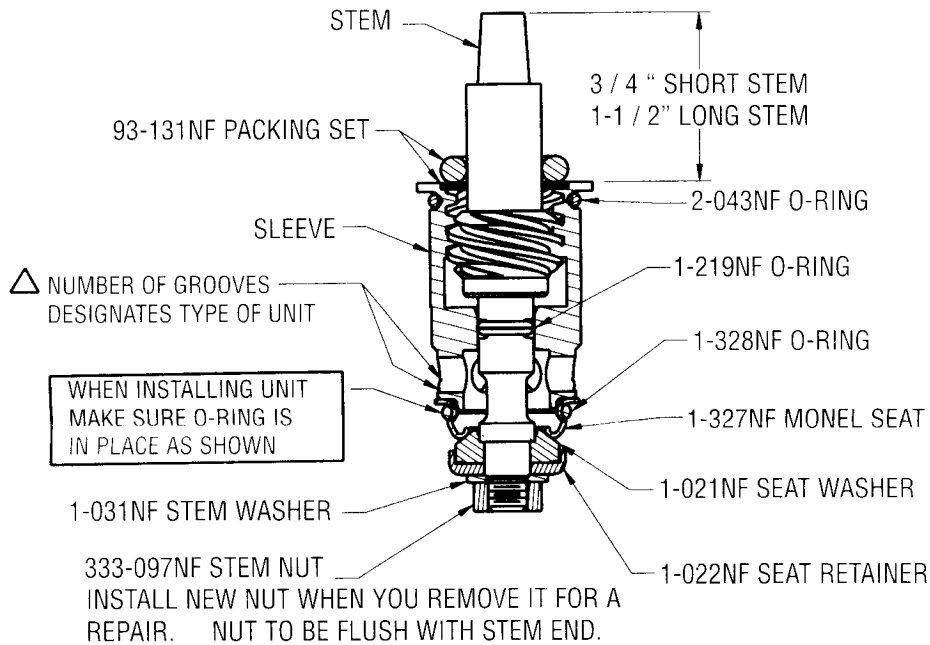

CAUTION: CLOSE UNIT BEFORE INSTALLING IN FAUCET BODY

- ✓ Before installing a new cartridge flush lines completely.
- ✓ Always have a new cartridge with the seat washer compressed against the seat (closed position) when installing into valve body.
- ✓ **To install RIGHT HAND cartridge:**
 - (1) Push cartridge into body until it seats
 - (2) Add cap nut and tighten HAND TIGHT
 - (3) Add handle and rotate it to the position desired (cartridge must remain closed)
 - (4) Fully tighten cap nut to 25 ft. lbs. torque
- ✓ **To install LEFT HAND cartridge:**
 - (1) Push cartridge into body until it seats
 - (2) Add cap nut and tighten HAND TIGHT
 - (3) Add handle and rotate it so that the seat washer is away from the seat (open)
 - (4) Rotate the handle to the position desired
 - (5) Fully tighten cap nut to 25 ft. lbs. torque
 - (6) Return handle to closed position
- ✓ Cap nut must be tightened to 25 ft. lbs. minimum so that the cartridge will not spin when the handle is turned in the open position
- ✓ Caution: Only clean faucet finish with SOAP AND WATER

△ GROOVE INDEX

- 1 GROOVE-RIGHT HAND, Quatum Cartridge
- 2 GROOVE-LEFT HAND, Quatum Cartridge
- 3 GROOVE-RIGHT HAND, Slo-Compression Cartridge
- 4 GROOVE-LEFT HAND, Slo-Compression Cartridge

Repair Kit 1277D - Cartridge Style 'X'

For Quatum and Slo-Compression Cartridges

The Kit Contains the following parts for the Style 'X' Cartridge: **Quantity**

- 1-119NF Packing Set (2)
- 1-043NF Gasket (2)
- 1-021NF Seat Washer (4)
- **333-097NF Stem Nut (new item included)** (4)
 - ♦ Install a new nut each time you remove it for a repair. The nut should be flush with the stem end.

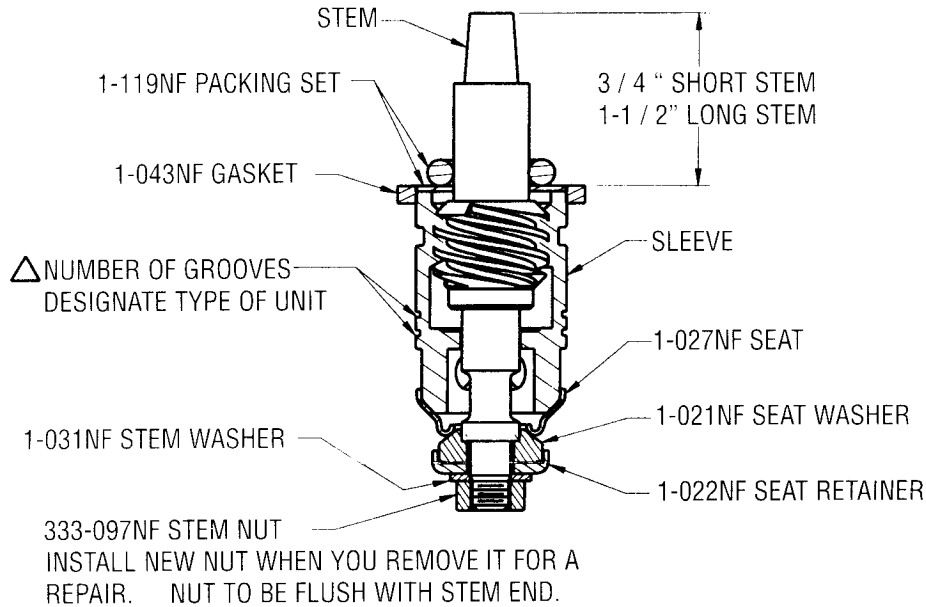

CAUTION: CLOSE UNIT BEFORE INSTALLING IN FAUCET BODY

- ✓ Before installing a new cartridge flush lines completely.
- ✓ Always have a new cartridge with the seat washer compressed against the seat (closed position) when installing into a valve body.
- ✓ **To install RIGHT HAND cartridge:**
 - (1) Push cartridge into body until it seats
 - (2) Add cap nut and tighten HAND TIGHT
 - (3) Add handle and rotate it to the position desired (cartridge must remain closed)
 - (4) Fully tighten cap nut to 25 ft. lbs. torque
- ✓ **To install LEFT HAND cartridge:**
 - (1) Push cartridge into body until it seats
 - (2) Add cap nut and tighten HAND TIGHT
 - (3) Add handle and rotate it so that the seat washer is away from the seat (open)
 - (4) Rotate the handle to the position desired
 - (5) Fully tighten cap nut to 25 ft. lbs. torque
 - (6) Return handle to closed position
- ✓ Cap nut must be tightened to 25 ft. lbs. minimum so that the cartridge will not spin when the handle is turned in the open position
- ✓ Caution: Only clean faucet finish with SOAP AND WATER

△ GROOVE INDEX

- 1 GROOVE-RIGHT HAND, Quatum Cartridge
- 2 GROOVE-LEFT HAND, Quatum Cartridge
- 3 GROOVE-RIGHT HAND, Slo-Compression Cartridge
- 4 GROOVE-LEFT HAND, Slo-Compression Cartridge