



WIRE REPLACEMENT INSTRUCTIONS
PART NUMBER 55288
EASY CHEESER

This Replacement Wire Kit contains enough wire to replace the wire in 55304 Cutting Bow (3/8) twice, or in 55303 Cutting Bow (3/4) four times. Replacement for Stainless Steel Screws (5) & (6) are included, but will only be needed if a screw gets damaged, or lost.

To replace the wire in the Cutting Bow Assembly, you will need the 55289 Tensioner contained in this Kit, a screwdriver, wire snips, and a clamp or vise (or the assistance of another person).

- 1) Remove the existing wire by loosening Screws (5) and (6) about 1 turn on both sides of bow.
- 2) Uncoil the replacement Wire, being very careful not to kink the wire. Measure and cut off the needed length of wire (5 feet for the 3/4" cut and 10 feet for the 3/8" cut" and recoil the unused length.
- 3) Secure the Cutting Bow to keep it from moving.
- 4) Leaving about a 4" tail, lightly fasten the wire under the head of Screw (5) as shown in Figure 1. Tighten the screw enough so the wire won't pull out, but it doesn't need to be real tight. Proceed to weave the wire around the posts (See Figure 1) and pull and hold it tight after each post is looped. (Leather gloves are recommended.) When the weaving is completed, secure the wire under the second Screw (5) to hold the tension. (Wrap under the head as shown in Figure 1.)
- 5) Place Tensioner (9) next to the Cutting Bow as shown in Figure 1. Wrap the Wire around Screw (10) and tighten the screw. Gently pull on the Tensioner (9) as shown in Figure 1 to maintain tension in the wire and loosen Screw (5). Continue to pull on the Tensioner (9) until the outer wire across the Cutting Bow "sings" when plucked, then again tighten Screw (5).

NOTE: The wire can be broken by over-tightening.

- 6) Place Tensioner (9) on the other side of the Cutting Bow, and repeat the procedure per 5) above. (See Figure 1)
- 7) Pull the wire ends about 3/4 of turn around the Screws (6) and tighten.
- 8) Cut off the wire ends. (You can break it off by "wiggling" against the screw heads.)

You will probably notice that the outer wires will "sing" more than the inner ones. This is common, but the unit will cut cheese effectively if the wires have been strung tightly as described in the fore-going instructions.

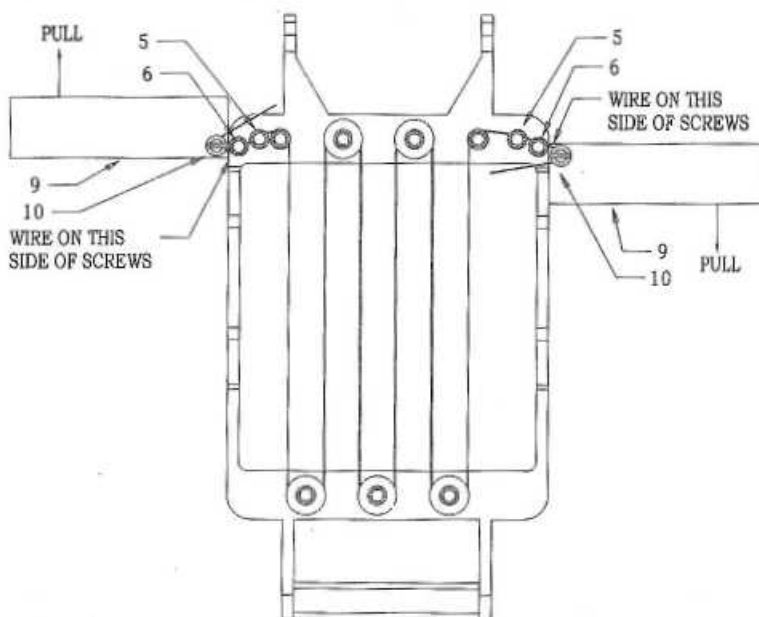

NEMCO FOOD EQUIPMENT 301 Meuse Argonne, Hicksville, OH 43526
Phone: (419) 542-7751 Fax: (419) 542-6690 Toll free: 1-800-782-6761

45500

www.nemcofoodequip.com

11/18/03