

RETROFIT KIT INSTRUCTIONS FOR INSTALLING ROTARY POWER SAVER

REMOVING OLD SWITCH:

- 1). **DISCONNECT UNIT FROM POWER SUPPLY.**
- 2). REMOVE RIGHT SIDE PANEL AND BOTTOM CONTROL BOX COVER.
- 3). REMOVE POWER SAVER KNOB BY LOOSENING TWO ALLEN SCREWS AND PULLING UPWARDS.
- 4). REMOVE PAL NUT WHICH HOLDS OLD SWITCH IN PLACE.
NOTE: DO NOT DISCONNECT WIRES FROM OLD POWER SAVER SWITCH.
- 5). REMOVE POWER SAVER LABEL BY PEELING LABEL OFF UNIT.

INSTALLING NEW SWITCH:

THE RETROFIT KIT WILL BE PROVIDED WITH THE FOLLOWING:

- 1 - ROTARY POWER SAVER SWITCH WITH WIRES ATTACHED.
- 1 - TWO PAL NUTS ON ROTARY POWER SAVER SWITCH.
- 1 - ROTARY POWER SAVER SWITCH LABEL.

- 1). PLACE NEW ROTARY POWER SAVER LABEL ON UNIT BY REMOVING LABEL BACKING AND PLACING OVER HOLE IN CHASSIS. WITH A SMALL KNIFE CUT OUT HOLE IN LABEL TO ALLOW NECK OF SWITCH TO PASS THROUGH.
- 2). REMOVE TOP PAL NUT FROM NECK OF NEW POWER SAVER SWITCH.
- 3). INSTALL NEW SWITCH INTO CHASSIS HOLE (switch will fit into hole in only one position).
- 4). SECURE SWITCH INTO PLACE WITH PAL NUT REMOVED IN STEP #3.
- 5). EACH WIRE ON THE NEW SWITCH IS NUMBERED. TRACING ONE WIRE AT A TIME, REPLACE THE OLD WIRES WITH THE NEW WIRES (DO NOT DISCONNECT THE NEW WIRES FROM THE NEW POWER SAVER SWITCH).

NOTE: IF THE OLD WIRES IN YOUR UNIT TERMINATE INTO A TERMINAL BLOCK, CUT THE TERMINALS OFF THE END OF THE WIRES AND STRIP BACK THE INSULATION. DISCONNECT ONE WIRE AT TIME FROM THE TERMINAL BLOCK AND REPLACE IT WITH THE WIRES FROM THE NEW POWER SAVER SWITCH.

- 6). INSTALL KNOB ON NEW SWITCH. THE BOTTOM SET SCREW WILL LINE UP WITH FLAT SPOT ON SHAFT AND KNOB WILL POINT AT THE FULL POWER POSTION.
- 7). REPLACE SIDE PANEL.
- 8). CONNECT UNIT TO POWER AND TEST FOR PROPER OPERATION. IF UNIT WILL NOT WORK, RECHECK CONNECTIONS OR CALL THE HOLMAN FACTORY SERVICE TEAM AT 1-800-225-3958 FOR ASSISTANCE.

WIRING DIAGRAM WITH TERMINAL BLOCK

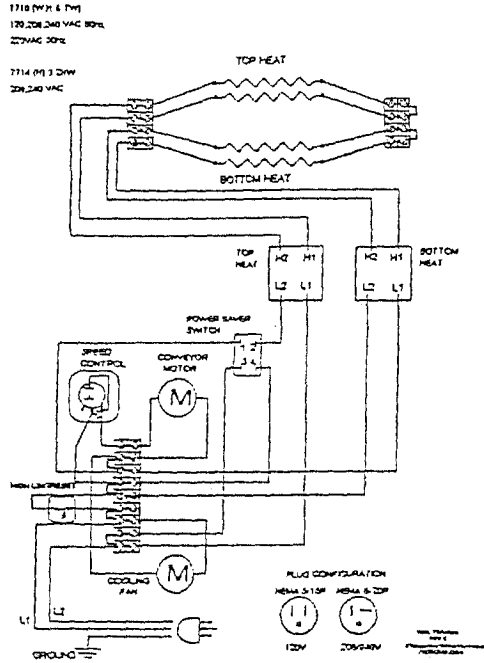

WIRING DIAGRAM WITHOUT TERMINAL BLOCK

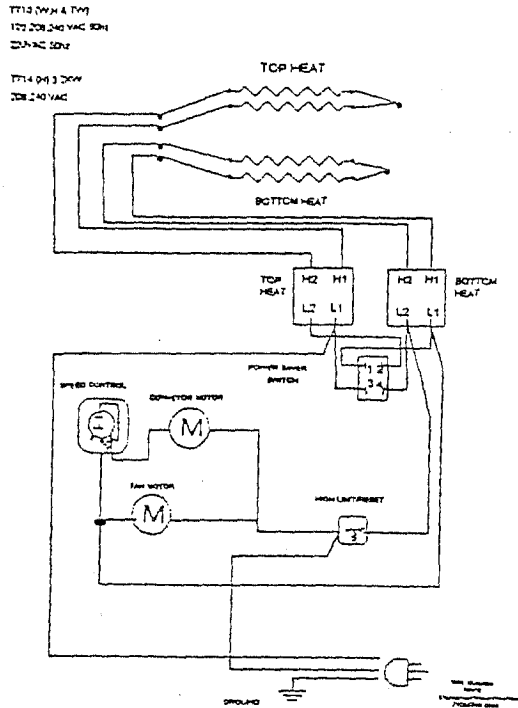

● NEW POWER SAVER CONNECTIONS SHOWN BELOW ●

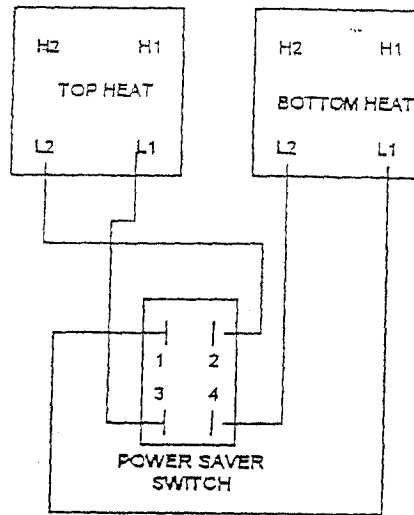
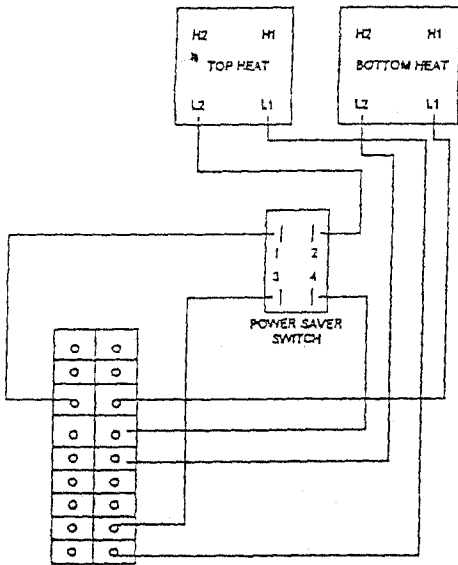

ROTARY POWER SAVER

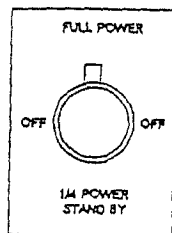

FULL POWER

